

E100H Series

Diameter ϕ 100mm hollow type INCREMENTAL Rotary encoder

■ Features

- Great endurance
- Stable output
- Only for elevator system

 Please read "Caution for your safety" in operation manual before using.



■ Ordering information

E100H	35	1024	6	2	5	
Series	Shaft diameter	Pulse/1Revolution	Output phase	Output	Power supply	Cable
Diameter ϕ 100mm hollow type	ϕ 35mm	See resolution	3 : A, B, Z 6 : A, \bar{A} , B, \bar{B} , Z, \bar{Z}	1 : Totem pole output 2 : NPN open collector output 3 : Voltage output L : Line driver output(※)	5 : 5VDC \pm 5% 24:12-24VDC \pm 5%	No mark:Normal type (※) 2C:Cable outgoing connector type

※The power of Line driver is only for 5VDC

※Cable length:200mm

■ Specifications

Item	Diameter ϕ 100mm hollow type Incremental Rotary encoder		
Resolution(P/R)	60, 100, 360, 500, 512, 1024 (Not indicated type is available to customize)		
Electrical specification	Output phase	A, B, Z phase (Line driver output A, \bar{A} , B, \bar{B} , Z, \bar{Z} phase)	
	Phase difference of output	Output between A and B phase : $\frac{T}{4} \pm \frac{T}{8}$ (T=1cycle of A phase)	
	Control output	Totem pole output	• Low \Rightarrow Load current : Max. 30mA, Residual voltage : Max. 0.4VDC • High \Rightarrow Load current : Max. 10mA, Output voltage : Min. (Power supply-1.5)VDC
		NPN open collector output	Load current : Max. 30mA, Residual voltage : Max. 0.4VDC
		Voltage output	Load current : Max. 10mA, Residual voltage : Max. 0.4VDC
		Line driver output	Low \Rightarrow Load current : Max. 20mA, Residual : Max. 0.5V High \Rightarrow Load current : Max. -20mA, Output voltage : Min. 2.5V
	Response time (Rise/Fall)	Totem pole output	Max. 1 μ s
		NPN open collector output	Max. 1 μ s
		Voltage output	Max. 1 μ s
		Line driver output	Max. 0.5 μ s
	Max. Response frequency	150kHz	
	Power supply	• 5VDC \pm 5% • 12-24VDC \pm 5%	
	Current consumption	Max. 60mA(disconnection of the load), Line driver output:Max. 50mA(disconnection of the load)	
	Insulation resistance	Min. 100M Ω (at 500VDC)	
Dielectric strength	750VAC 50/60Hz for 1 minute (Between all terminals and case)		
Connection	Cable outgoing type, 200mm cable outgoing connector type		
Mechanical specification	Starting torque	Max. 200gf \cdot cm(0.02N \cdot m)	
	Moment of inertia	Max. 800g \cdot cm ² (8 \times 10 ⁻⁵ kg \cdot m ²)	
	Shaft loading	Radial : 5kgf, Thrust : 2.5kgf	
	Max. allowable revolution	(★Note1) 3600rpm	
Vibration	1.5mm amplitude at frequency of 10 ~ 55Hz in each of X, Y, Z directions for 2 hours		
Shock	Max. 75G		
Ambient temperature	-10 ~ 70 $^{\circ}$ C (at non-freezing status), Storage:-25 ~ 85 $^{\circ}$ C		
Ambient humidity	35~85%RH, Storage:35~90%RH		
Protection	IP50(IEC specification)		
Cable	7P, ϕ 5mm, Length:5m, Shield cable (Line driver output:10P, ϕ 7mm, Length:5m)		
Accessory	Spring bracket 2EA		
Weight	Approx. 1200g		
Approval	CE (Except Line driver output)		

※ (★Note1) Max. allowable revolution \geq Max. response revolution **[Max. response revolution(rpm) = $\frac{\text{Max. response frequency}}{\text{Resolution}} \times 60 \text{ sec}$]**

Please select the resolution to make lower max. revolution than max. allowable revolution.

φ 100 Heavy Duty Hollow Shaft Type

Control output diagram

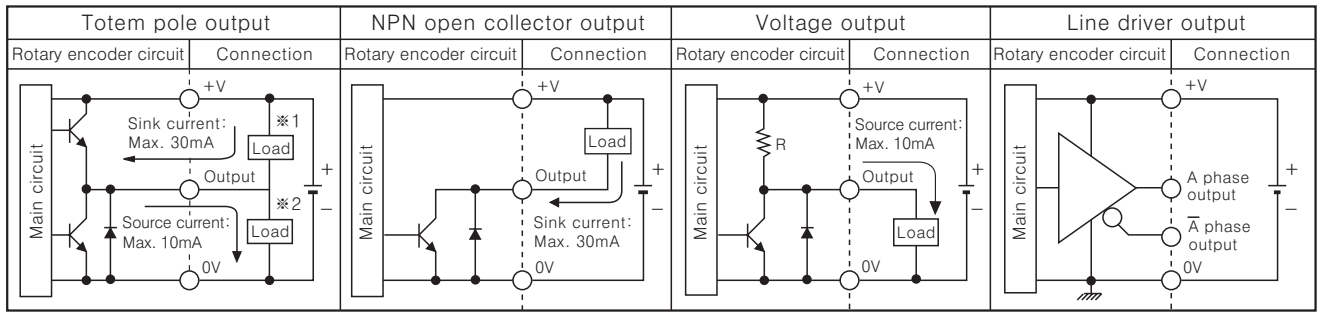

⇒ Totem pole output type can be used for NPN open collector output type(*1) or Voltage output type(*2).
 ⇒ All output circuits are the same A, B, Z phase(Line driver output is A, \bar{A} , B, \bar{B} , Z, \bar{Z})

Connections

Normal type

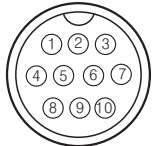

DC-20-10-RN

Pin No.	Cable color	Totem pole output NPN open collector output Voltage output	Line driver output
①	Black	OUT A	OUT A
②	Red	N.C	OUT \bar{A}
③	Brown	+V	+V
④	Blue	GND	GND
⑤	White	OUT B	OUT B
⑥	Gray	N.C	OUT \bar{B}
⑦	Orange	OUT Z	OUT Z
⑧	Yellow	N.C	OUT \bar{Z}
⑨	Shield	F.G	F.G
⑩	Purple	N.C	N.C

*N.C(Not Connected)
 *F.G(Field Ground)

Elevator(Optional)

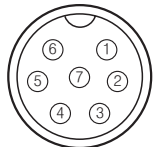

SCN-16-7P

Pin No.	Cable color	Function
①	Red	+V
②	Black	0V
③	White	OUT A
④	Yellow	OUT A GND
⑤	Orange	OUT B
⑥	Green	OUT B GND
⑦	Shield	F.G

*Un used wires must be insulated.
 *The shield wire and metal case of encoder must be grounded(F.G).

Cable outgoing connector type

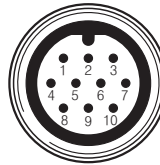

Pin No.	Cable color	Totem pole output NPN open collector output Voltage output	Line driver output
①	Black	OUT A	OUT A
②	Red	N.C	OUT \bar{A}
③	Brown	+V	+V
④	Blue	GND	GND
⑤	White	OUT B	OUT B
⑥	Gray	N.C	OUT \bar{B}
⑦	Orange	OUT Z	OUT Z
⑧	Yellow	N.C	OUT \bar{Z}
⑨	Shield	F.G	F.G
⑩	Purple	N.C	N.C

*N.C(Not Connected)
 *F.G(Field Ground)

Output waveform

● Totem pole output / NPN open collector output / Voltage output

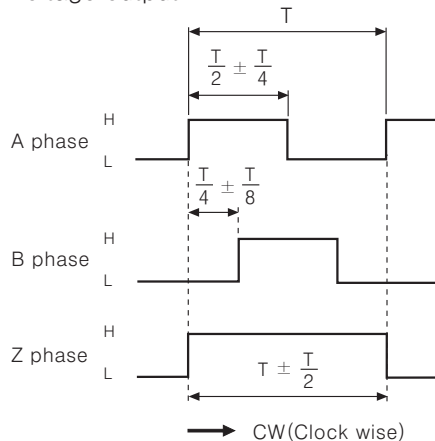

*CW : In a view of shaft

● Line driver output

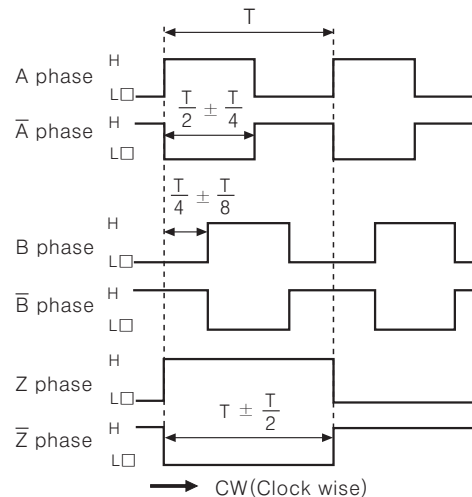

*CW(Clock wise)

(A) Counter

(B) Timer

(C) Temp. controller

(D) Power controller

(E) Panel meter

(F) Tacho/Speed/Pulse meter

(G) Display unit

(H) Sensor controller

(I) Proximity sensor

(J) Photo electric sensor

(K) Pressure sensor

(L) Rotary encoder

(M) 5-Phase stepping motor & Driver & Controller

E100H Series

■ Dimensions

■ Connector type

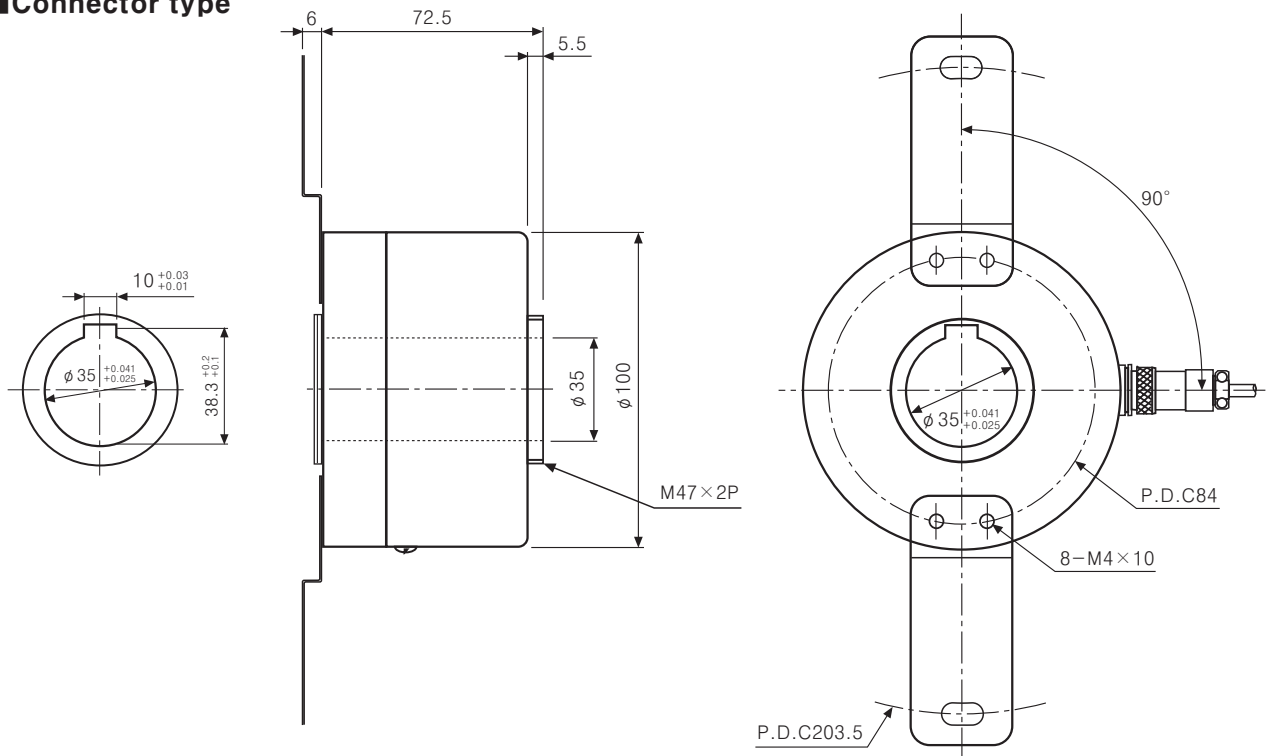

● Connector cable

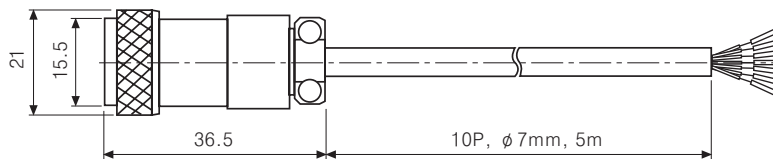

- ※When it is for elevator, connector cable is 7P, ϕ 7mm, 5m.
- ※Connector cable is 10m (Option).
- ※Cable outgoing type is optional.

● Spring bracket

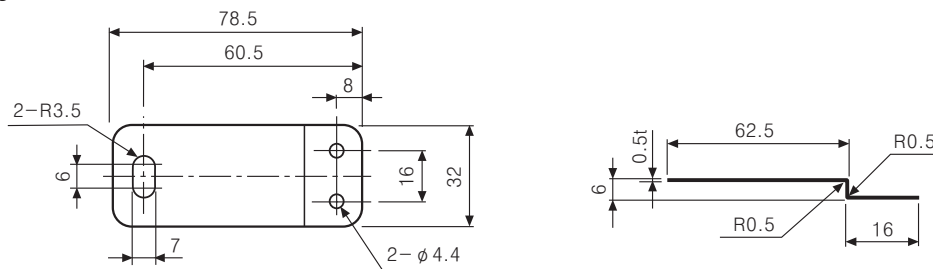

■ Cable outgoing connector type

● Connector cable (Accessory)

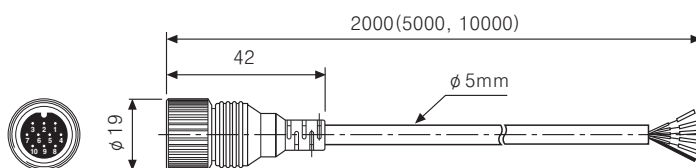

	Connector cable model	Connector cable model
Line driver output	EC8-2(Standard), EC8-5, EC8-10	EC 5 - 2
Etc.	EC5-2(Standard), EC5-5, EC5-10	<ul style="list-style-type: none"> └ Cable length (m) └ The number of cables └ Connector cable of Encoder

※A cable length is optional.

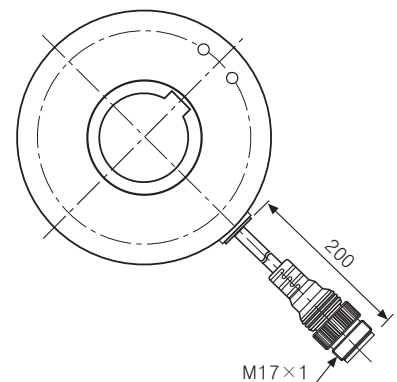

Unit:mm