



PC-900 type



- Applicable 10-pattern, 100-step max.
- Accuracy: Within $\pm 0.2\%$ of full scale ± 1 digit
- Input sampling period: 0.125s
- Multi-range/Multi-function
- The transient characteristic of the control when changing the step has been improved by Fuzzy algorithm.
- CE marking conformity

Shinko

Program control

Settable maximum 10-step per pattern. When linking the pattern, the setting is possible up to 100-step.

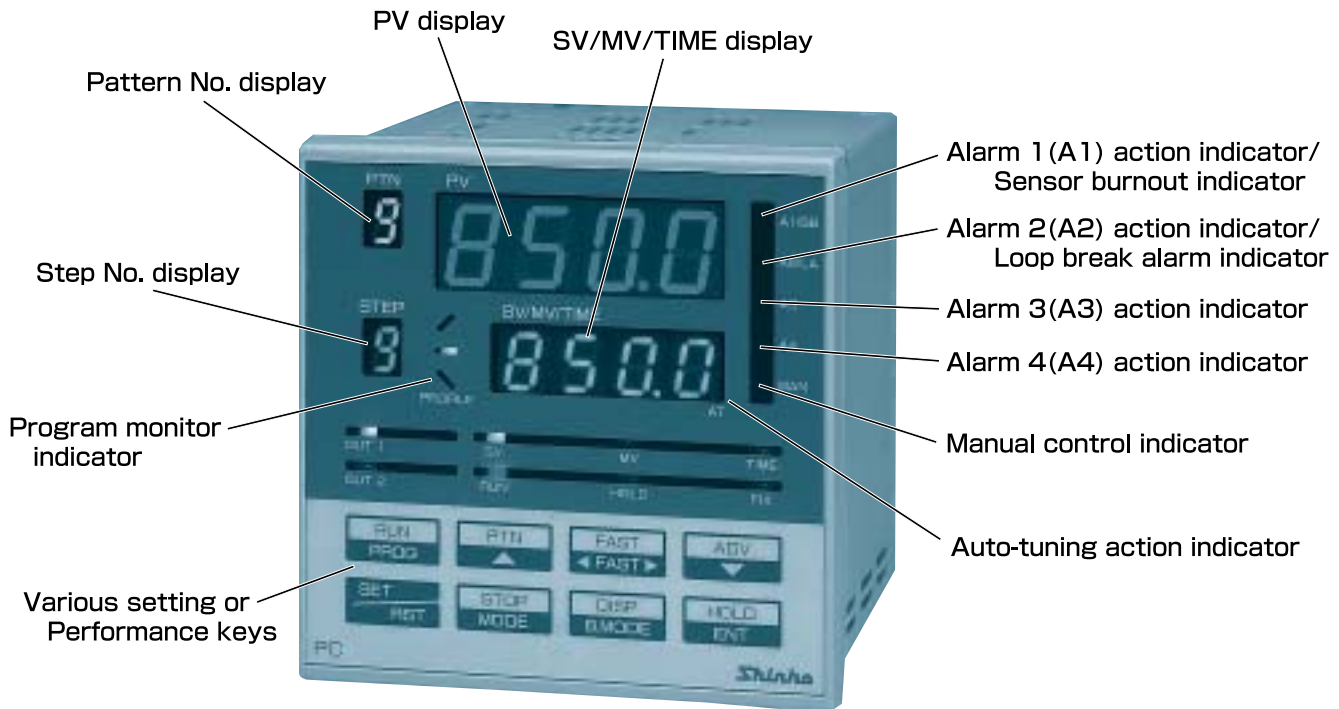
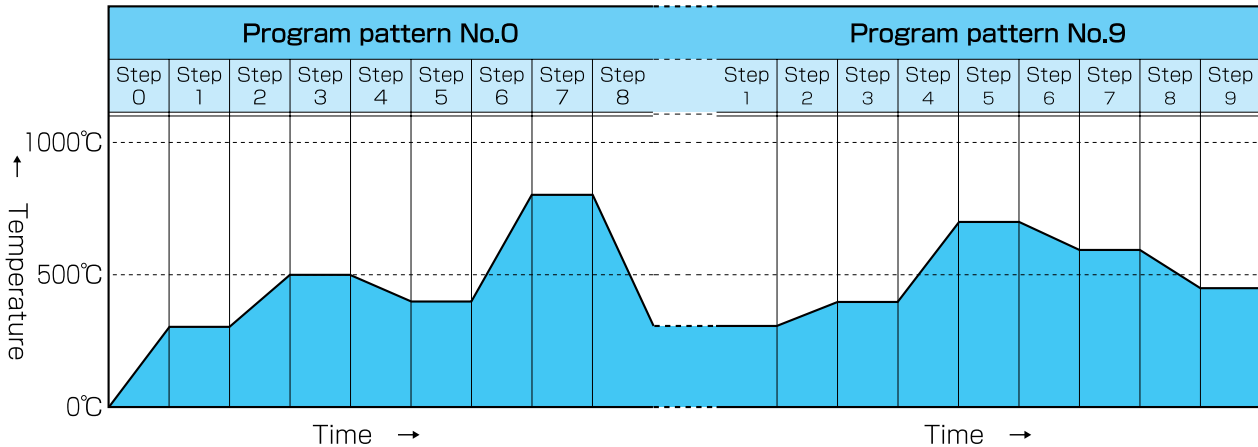

Model names

P C - 9 □ 5 - □ / M, □ □ □ □		Type name: PC-900 [96(W)×96(H)×100(D)mm
Control action	3	PID (Type is selectable)
	5	ON/OFF servo output PID (Type is selectable)
Alarm 1(A1)	5	Multi-action system (Type is selectable)
Control output	R	Relay contact: 1a1b, or 1a×2
	S	Non-contact voltage (for SSR drive): 12 ⁺ ₀ Vdc
	A	Current: 4 to 20mAcd
Input	M	Multi-range system (Type is selectable)
Option	A2	Alarm 2 (A2) (Type is selectable)
	LA	Loop break alarm
	DR	Control output (OUT2)
	DS	(Heating and Cooling control)
	DA	Relay contact: 1a Non-contact voltage (for SSR drive) Current: 4 to 20mAcd
	TA	Transmission
	TV	output
	C	Serial communication
	C5	RS-232C RS-485
	SVTC	Main setting value digital transmission
	TS	Time signal
	IP	Dust-proof · Drip-proof (IP54)
	TC	Terminal cover
BK	Color black	

Rated scale

Input type		Scale	
Thermocouple	K	-200 to 1370 °C	-320 to 2500 °F
	J	-200 to 1000 °C	-320 to 1800 °F
	R	0 to 1760 °C	0 to 3200 °F
	S	0 to 1760 °C	0 to 3200 °F
	B	0 to 1820 °C	0 to 3300 °F
	E	0 to 1000 °C	0 to 1800 °F
	T	-199.9 to 400.0 °C	-199.9 to 750.0 °F
	C (W/Re5-26)	0 to 2315 °C	0 to 4200 °F
	N	0 to 1300 °C	0 to 2300 °F
	PL-2	0 to 1390 °C	0 to 2500 °F
RTD	Pt100	-199.9 to 850.0 °C	-199.9 to 999.9 °F
	Pt100	-200 to 850 °C	-320 to 1560 °F
	JPt100	-199.9 to 500.0 °C	-199.9 to 900.0 °F
Current	4 to 20mA	-1999 to 9999 (Decimal point place is changeable, and the scaling is possible.)	
	0 to 20mA		
Voltage	0 to 1V		

Standard specifications

Input	Thermocouple: K, J, R, S, B, E, T, C(W/Re5-26), N, PL-2 External resistance: 100 Ω or less		
	RTD	: Pt100, JPt100	3-wire system (10 Ω or less)
	Current	: 4 to 20mA _{dc} , 0 to 20mA _{dc}	Input impedance: 50 Ω
	Voltage	: 0 to 1V _{dc}	Input impedance: 1M Ω or greater
	Scale	: Refer to the Rated scale.	
	Resolution	<ul style="list-style-type: none"> • Thermocouple (excepting T type), RTD : 1°C (1°F) • When decimal point is applied : 0.1°C (0.1°F) • Current, Voltage : 1 (Decimal point place is changeable, and the scaling is possible.) 	
Accuracy (Setting and Indication)	Within ±0.2% of full scale ±1digit, however, <ul style="list-style-type: none"> • K, J or T : Less than 0°C (32°F) ----- Within ±0.4% of full scale ±1digit • R, S : 0 to 200°C (400°F) ----- Within ±4°C (8°F) • B : 0 to 300°C (600°F) ----- Without the range of accuracy guarantee (The cold junction compensating accuracy ±1°C ----- 0 to 50°C) 		
Time indicating accuracy	Within ±0.1% of setting time		
Control action	Selectable by internal switch. <ul style="list-style-type: none"> • Fuzzy overshoot suppression PID (with auto-tuning function) • PID (with auto-tuning function) <ul style="list-style-type: none"> Proportional band (P): 0.0 to 999.9% (Setting the value to 0.0 causes the controller to act as an ON/OFF controller.) ON/OFF action Hysteresis ----- When applied thermocouple or RTD input, 0.1 to 100.0°C (°F). When applied DC input, 1 to 1000.(Decimal point place follows the selection.) 		
	Integral time (I)	: 0 to 3600s (off when set to 0)	
	Derivative time (D)	: 0 to 1800s (off when set to 0)	
	Proportional cycle	: 1 to 120s (not available when control output type is current)	
	ARW	: 0 to 100%	
	Output limiter	: 0 to 100% (In case of Current, it is —5 to 105%)	
	Dead band	: 0.1 to 100% of proportional band (only PC-955)	
	Open output time	: 0.1 to 999.9s (only PC-955)	
	Closed output time	: 0.1 to 999.9s (only PC-955)	
Control output (OUT1)	Relay contact	: 1a1b 250Vac 3A (Resistive load), 250Vac 1A (Inductive load cos φ =0.4)	
	Non-contact voltage	: 12V _{dc} 40mA max. (short circuit protected)	
	Current	: 4 to 20mA _{dc} (Isolated type) Load resistance: 550 Ω max.	
	Relay contact	: 1a ×2 250Vac 3A (Resistive load), 250Vac 1A (Inductive load cos φ =0.4) (for control motor, only PC-955)	
Alarm 1 (A1), Alarm 3 (A3), Alarm 4 (A4)	Types	: Setting range	
	<ul style="list-style-type: none"> • No function • High limit action (Deviation setting): ±Input range span (off when set to 0) • Low limit action (Deviation setting): ±Input range span (off when set to 0) • High/Low limits action (Deviation setting): 0 to input range span (off when set to 0) • High/Low limit range action (Deviation setting): 0 to input range span (off when set to 0) • Process high action : Input range min. to Input range max. • Process low action : Input range min. to Input range max. 		
	Standby function	: Selectable	
	Alarm action delayed timer	: Applicable (Setting range ----- 0 to 9999s)	
	Setting accuracy	: Within ±0.2% of full scale ±1digit	
	Control action	: ON/OFF action	
	Hysteresis	: In case of thermocouple or RTD input : 0.1 to 100.0°C (°F) : In case of DC input : 1 to 1000 (Decimal point place follows the selection.)	
	Control output	: Relay contact 1a (In case of Alarm 3, 4 : 1a×2) 250Vac 3A (Resistive load), 250Vac 1A (Inductive load cos φ =0.4) (Common terminal [A3, A4]: 3A max.)	
Input sampling period	0.125s	Instantaneous power failure	30ms or greater
Supply voltage	100 to 240Vac 50/60Hz, 24Vac/dc 50/60Hz	Insulation resistance	10M Ω or greater at 500V _{dc}
Allowable voltage fluctuation	In case of 100 to 240Vac, 85 to 264Vac In case of 24Vac/dc, 20 to 28Vac/dc	Dielectric strength	Between input terminal and ground terminal1.5kVac for 1 minute
Power consumption	Approx. 15VA		Between input terminal and power terminal 1.5kVac for 1 minute
Ambient temperature	0 to 50 °C		Between power terminal and ground terminal1.5kVac for 1 minute
Ambient humidity	35 to 85%RH (non-condensing)	Case	Between output terminal and ground terminal1.5kVac for 1 minute
External dimension	96×96×100mm (W×H×D)	Panel	Between output terminal and power terminal1.5kVac for 1 minute
Mounting method	Flush	Weight	Approx. 500g
Attached function	Setting value lock, Setting value limit, Sensor correction, Multi range, Alarm action delayed timer, Multi function, Warm-up indication, Wait, Hold, Advance, Back advance, Repeat, Link, Time fast change, Data clear, Pattern number external selection, External operation, Power failure countermeasure, Fixed value control, Self-diagnosis, Automatic cold junction temperature compensation, Sensor burnout alarm, PV start		
Option	Alarm 2 (A2) [A2], Loop break alarm [LA], Heating and Cooling control [Control output (OUT2)] [DR, DS, DA], Transmission output [TA, TV], Serial communication [C, C5], Main setting value digital transmission [SVTC], Time signal [TS], Dust-proof · Drip-proof [IP], Terminal cover [TC], Color black [BK] The Alarm 2 (A2) [A2] and Heating/Cooling control [Control output (OUT2)] [DR, DS, DA] cannot be applied to PC-955.		

Program performance

Number of pattern	10 (can be linked)
Number of step	100 (10 steps/Pattern)
Number of repeat	0 to 9999 times
Program time range	0 to 99hours: 59min./step, or 0 to 99min. : 59sec./step
Time setting accuracy	Within ±0.1% of setting time
Wait value	±(0 to 100)°C (°F) (no wait action when set to 0), however,
	In case of with decimal point : ±(0.0 to 100.0) In case of DC input : ±(0 to 1000) (Decimal point place follows the selection.)

Multi-range/Multi-function

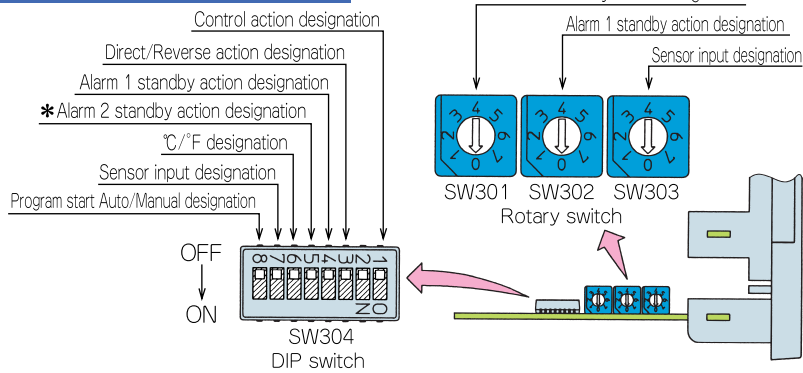

Item	Switch No.	Contents	Switch Status
Control action	1	PID action	OFF
		Fuzzy overshoot suppression PID action	ON
Direct/Reverse action	3	Reverse (Heating) action	OFF
		Direct (Cooling) action	ON
Alarm 1 (A1) standby function	4	No standby function	OFF
		Standby function	ON
Alarm 2 (A2) standby function *	5	No standby function	OFF
		Standby function	ON
C/F change	6	C	OFF
		F	ON
Sensor input	7	K, J, R, B, N, PL-2, Pt100, JPt100 (with decimal point)	OFF
		S, E, T, C, 4 to 20mA, 0 to 20mA, 0 to 1V, Pt100 (no decimal point)	ON
Program start Auto/Manual	8	Manual start	OFF
		Automatic start	ON

* Not applicable to PC-955 type.

Terminal arrangement

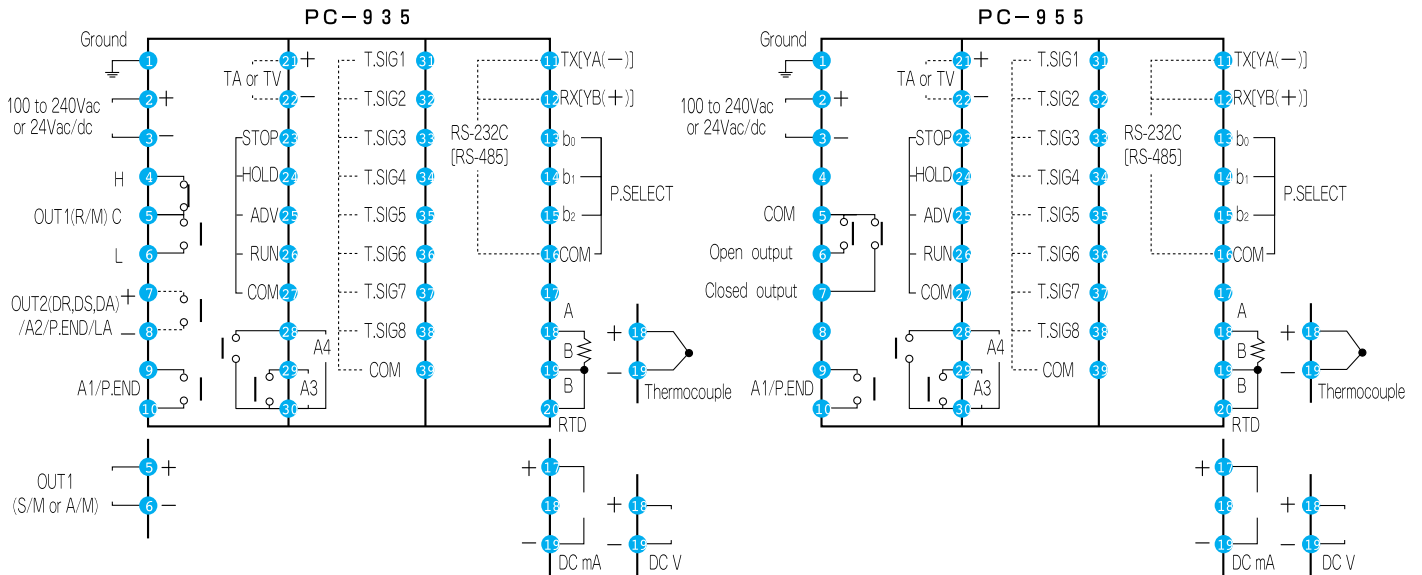

- Attention**
- A1 to A4 : Alarm 1 (A1) to Alarm 4 (A4)
 - OUT1, OUT2: Control output (OUT1), Control output (OUT2, Heating/Cooling control)
 - DR, DS, DA : Heating/Cooling control (Relay contact output, Non-contact voltage output, Current output)
 - TA, TV : Transmission output
 - LA : Loop break alarm
 - P.SELECT : Pattern number external selection
 - P.END : Pattern end output
 - T.SIG : Time signal
 - Dotted line shows the option, no terminal is equipped if it is not specified.

External dimension drawing

(When using the terminal cover [Option code: TC].)
Panel thickness, 1 to 15mm

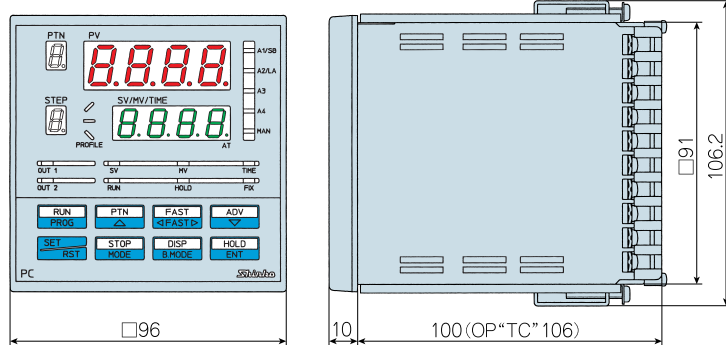

Panel cutout drawing

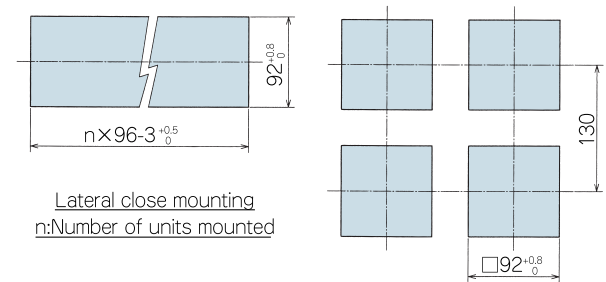

- The contents of this catalog is as of August 2002, and the specifications subject to without notice.
- When inquiring, please consult your shop where purchased or our agency.

SHINKO TECHNOS CO., LTD. OVERSEAS DIVISION

Head Office: 1-7-46, Sakai, Osaka 592-0015, Japan
 Mail Address: P.O. Box 17, Sakai, Osaka, Japan
 Tel: 011-727-7111, 7101
 Fax: 011-727-7411, 7400
 E-Mail: shinko@shinko-technos.co.jp
 URL: http://www.shinko-technos.co.jp