

E50S8

Diameter ϕ 50mm shaft type INCREMENTAL Rotary encoder

■ Features

- Suitable for Angle, Position, Revolution, Speed, Acceleration, Distance detection
- Power supply : 5VDC, 12-24VDC \pm 5%
- Cost effective

■ Applications

- Various tooling machinery, packing machine and general industrial machinery etc.

! Please read "Caution for your safety" in operation manual before using.



■ Ordering information (Former name : ENB)

E50S	8	5000	3	2	24	
Series	Shaft diameter	Pulse/1Revolution	Output phase	Output	Power supply	Cable
Diameter ϕ 50mm, shaft type	ϕ 8mm	See resolution	2 : A, B 3 : A, B, Z (Standard) 4 : A, \bar{A} , B, \bar{B} 6 : A, \bar{A} , B, \bar{B} , Z, \bar{Z}	1: Totem pole output 2: NPN open collector output 3: Voltage output L: Line driver output(*)	5 : 5VDC \pm 5% 24 : 12-24VDC \pm 5%	No mark: Normal type (*) 2C: Cable outgoing connector type

*Standard: E50S8-PULSE-3-2-24(12-24VDC) *Standard: A, B, Z *The power of Line driver is only for 5VDC *Cable length : 200mm

■ Specifications

Item		Diameter ϕ 50mm shaft type Incremental Rotary encoder		
Resolution(P/R)		(*Note1) *1, *2, *5, 10, *12, 15, 20, 23, 25, 30, 35, 40, 45, 50, 60, 75, 100, 120, 150, 192, 200, 240, 250, 256, 300, 360, 400, 500, 512, 600, 800, 1000, 1024, 1200, 1500, 1800, 2000, 2048, 2500, 3000, 3600, 5000 (Not indicated type is available to customize)		
Electrical specification	Output phase	A, B, Z phase (Line driver : \bar{A} , \bar{A} , B, \bar{B} , Z, \bar{Z} phase)		
	Phase difference of output	Output between A and B phase : $\frac{T}{4} \pm \frac{T}{8}$ (T=1 cycle of A phase)		
	Control output	Totem pole output	• Low \Rightarrow Load current : Max. 20mA, Residual voltage : Max. 0.5VDC • High \Rightarrow Load current : Max. -20mA, Output voltage : Min. (Power supply-1.5)VDC	
		NPN open collector output	Load current : Max. 30mA, Residual voltage : Max. 0.4VDC	
		Voltage output	Load current : Max. 10mA, Residual voltage : Max. 0.4VDC	
		Line driver output	Low \Rightarrow Load current : Max. 20mA, Residual : Max. 0.5V High \Rightarrow Load current : Max. -20mA, Output voltage : Min. 2.5V	
	Response time (Rise/Fall)	Totem pole output	Max. 1 μ s	
		NPN open collector output	Max. 1 μ s	
		Voltage output	Max. 1 μ s	
		Line driver output	Max. 0.5 μ s	
Max. Response frequency	180kHz			
Current consumption	Max. 60mA (disconnection of the load), Line driver output: Max. 50mA (disconnection of the load)			
Insulation resistance	Min. 100M Ω (at 500VDC)			
Dielectric strength	750VAC 50/60Hz for 1 minute (Between all terminals and case)			
Connection	Cable outgoing type, 200mm cable outgoing connector type			
Mechanical specification	Starting torque	(*Note2)	Max. 70gf \cdot cm (0.007N \cdot m)	
	Moment of inertia		Max. 80g \cdot cm ² (8 \times 10 ⁻⁶ kg \cdot m ²)	
	Shaft loading		Radial : Max. 10kgf, Thrust : Max. 2.5kgf	
	Deviation of shaft position		Radial : Max. 0.1mm, Thrust : Max. 0.2mm	
	Max. allowable revolution	(*Note3)	5000rpm	
Vibration	1.5mm amplitude at frequency of 10 ~ 55Hz in each of X, Y, Z directions for 2 hours			
Shock	Max. 75G			
Ambient temperature	-10 ~ 70 $^{\circ}$ C (at non-freezing status), Storage: -25 ~ 85 $^{\circ}$ C			
Ambient humidity	35~85%RH, Storage: 35~90%RH			
Protection	IP50 (IEC specification)			
Cable	5P, ϕ 5mm, Length : 2m, Shield cable (Line driver output : 8P, ϕ 5mm)			
Accessory	ϕ 8mm coupling bracket			
Weight	Approx. 275g			
Approval	(Except Line driver output)			

*(*Note1) *1 pulse is only for A, B phase (Line Driver output is \bar{A} , \bar{A} , B, \bar{B} phase)

*(*Note1) The lower torque than rated torque is optional.

*(*Note3) Max. allowable revolution \geq Max. response revolution **[Max. response revolution (rpm) = $\frac{\text{Max. response frequency}}{\text{Resolution}} \times 60 \text{ sec}$]**

Please select the resolution to make lower max. revolution than max. allowable revolution.

∅ 50 Medium Duty Standard Shaft Type

Control output diagram

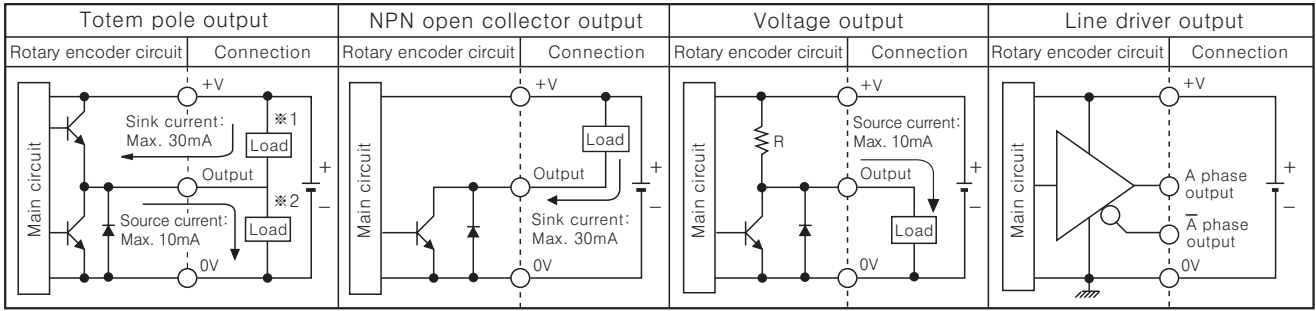

⇒ Totem pole output type can be used for NPN open collector output type(※1) or Voltage output type(※2).
 ⇒ All output circuits are the same A, B, Z phase(Line driver output is A, \bar{A} , B, \bar{B} , Z, \bar{Z})

Output waveform

- Totem pole output / NPN open collector output / Voltage output
- Line driver output

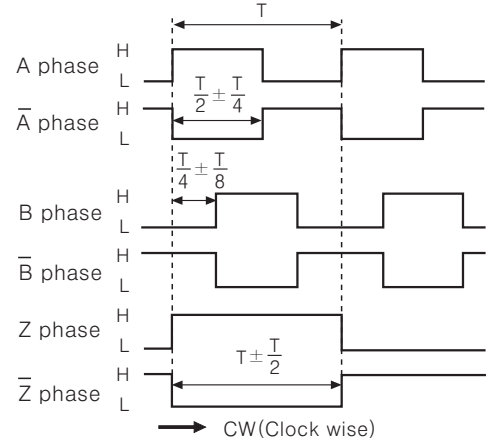
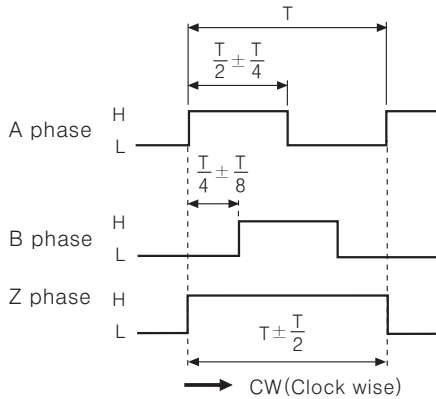

※CW : In a view of shaft

Connections

Normal type

- Totem pole output / NPN open collector output / Voltage output

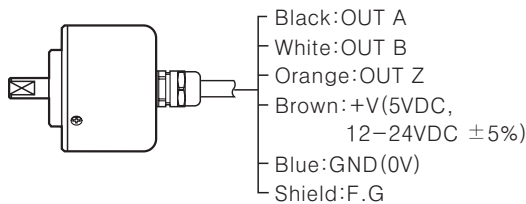

- ※ Unused wires must be insulated.
- ※ The shield wire and metal case of encoder must be grounded(F.G)

- Line driver output

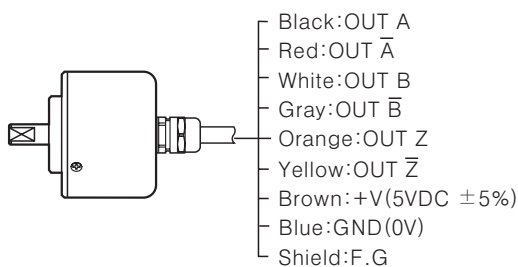

Cable outgoing connector type

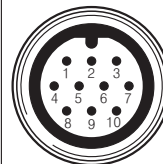

Pin No.	Cable color	Totem pole output NPN open collector output Voltage output	Line driver output
①	Black	OUT A	OUT A
②	Red	N.C	OUT \bar{A}
③	Brown	+V	+V
④	Blue	GND	GND
⑤	White	OUT B	OUT B
⑥	Gray	N.C	OUT \bar{B}
⑦	Orange	OUT Z	OUT Z
⑧	Yellow	N.C	OUT \bar{Z}
⑨	Shield	F.G	F.G
⑩	Purple	N.C	N.C

※ N.C(Not Connected)
 ※ F.G(Field Ground)

(A) Counter

(B) Timer

(C) Temp. controller

(D) Power controller

(E) Panel meter

(F) Tacho/Speed/Pulse meter

(G) Display unit

(H) Sensor controller

(I) Proximity sensor

(J) Photo electric sensor

(K) Pressure sensor

(L) Rotary encoder

(M) 5-Phase stepping motor & Driver & Controller

E50S8

Dimensions

Normal type

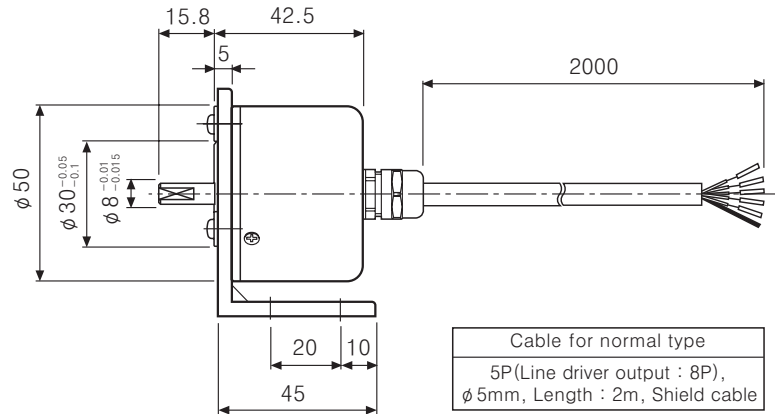
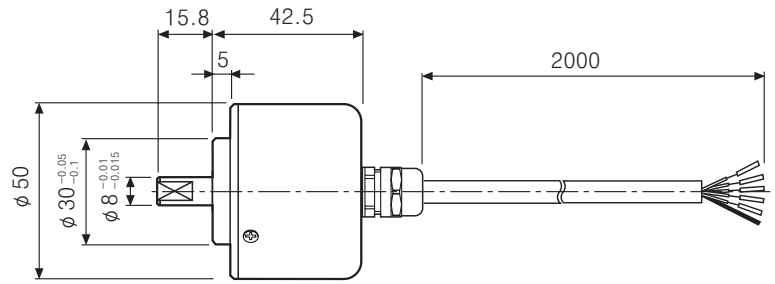
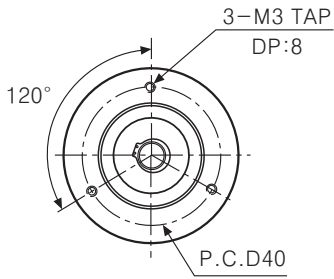

Cable for normal type
5P(Line driver output : 8P),
ø5mm, Length : 2m, Shield cable

Cable outgoing connector type

- Connector cable (Accessory)

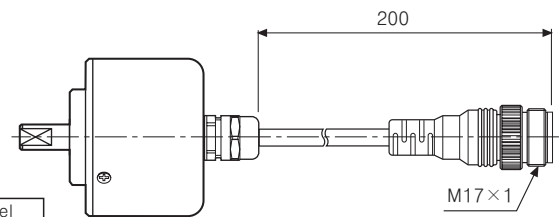
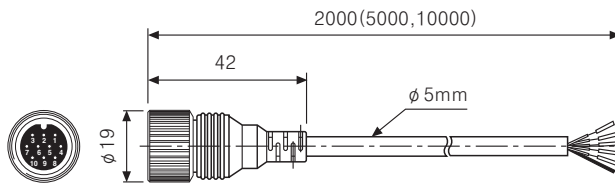

Connector cable model	
Line driver output	EC8-2(Standard), EC8-5, EC8-10
Etc.	EC5-2(Standard), EC5-5, EC5-10

Connector cable model	
EC	5 - 2
	Cable length(m)
	The number of cables
	Connector cable of Encoder

*A cable length is optional.

- Bracket

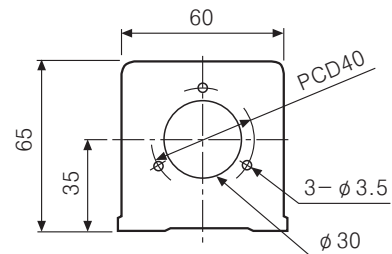
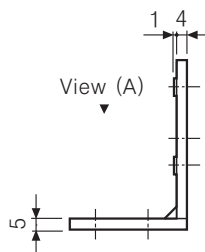
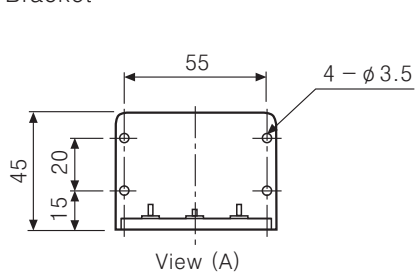

- Coupling

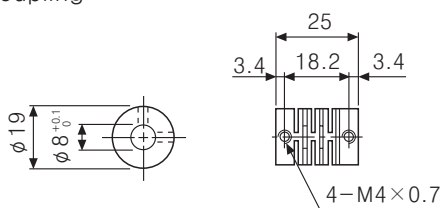

Unit:mm