

# φ 40 Body Standard / Hollow Shaft Type

## Diameter φ 40mm Shaft type/Hollow type/Built-in type INCREMENTAL Rotary encoder

### Features

- Easy installation at narrow space
- Small inertia moment
- Wide range of power source :  
5VDC, 12-24VDC ±5%
- Various output types

**⚠ Please read "Caution for your safety" in operation manual before using.**

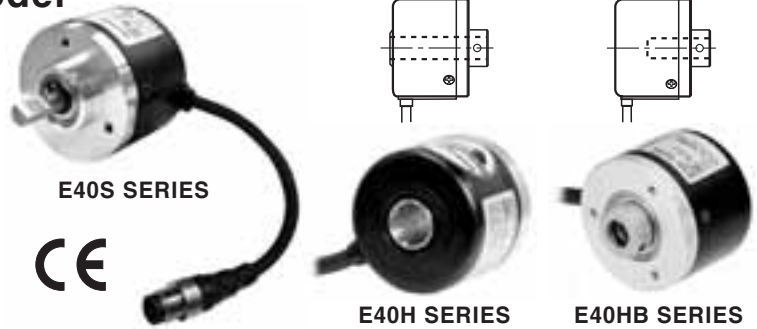

### Ordering information

**E40** **H** **8** **5000** **3** **2** **24**

Series	Shaft type	Hollow type	Pulse/1 Revolution	Output phase	Output	Power supply	Cable
S: Shaft type	Outside	Inside	See resolution	2:A, B 3:A, B, Z 4:A, $\bar{A}$ , B, $\bar{B}$ 6:A, $\bar{A}$ , B, $\bar{B}$ , Z, $\bar{Z}$	1: Totem pole output 2: NPN open collector output 3: Voltage output L: Line driver output(*)	5 :5VDC ±5% 24:12-24VDC ±5%	No mark: Normal type (*) 2C: Cable outgoing connector type
H: Hollow type	(*)	6: φ 6mm 8: φ 8mm					
HB: Hollow built-in type	6: φ 6mm 8: φ 8mm	10: φ 10mm 12: φ 12mm					

\*Standard : E40S6-[PULSE]-3-2-24  
E40H8-[PULSE]-3-2-24  
E40HB8-[PULSE]-3-2-24 } 12-24VDC

\*Standard:A, B, Z \*The power of Line driver is only for 5VDC

\*Cable length : 200mm

### Specifications

Item		Diameter φ40mm shaft type Incremental Rotary encoder		
Resolution(P/R)		(*Note1) *1, *2, *5, 10, *12, 15, 20, 23, 25, 30, 35, 40, 45, 50, 60, 75, 100, 120, 150, 192, 200, 240, 250, 256, 300, 360, 400, 500, 512, 600, 800, 1000, 1024, 1200, 1500, 1800, 2000, 2048, 2500, 3000, 3600, 5000 (Not indicated type is available to customize)		
Electrical specification	Phase difference of output	Output between A and B phase : $\frac{T}{4} \pm \frac{T}{8}$ (T=1cycle of A phase)		
	Control output	Totem pole output	• Low ⇔ Load current : Max. 30mA, Residual voltage : Max. 0.4VDC • High ⇔ Load current : Max. 10mA, Output voltage : Min. (Power supply-1.5)VDC	
		NPN open collector output	Load current : Max. 30mA, Residual voltage : Max. 0.4VDC	
		Voltage output	Load current : Max. 10mA, Residual voltage : Max. 0.4VDC	
		Line driver output	Low ⇔ Load current : Max. 20mA, Residual : Max. 0.5V High ⇔ Load current : Max. -20mA, Output voltage : Min. 2.5V	
	Response time (Rise/Fall)	Totem pole output	Max. 1μs	
		NPN open collector output	Max. 1μs	
		Voltage output	Max. 1μs	
		Line driver output	Max. 0.5μs	
	Max. Response frequency	180kHz		
Current consumption	Max. 60mA(disconnection of the load), Line driver output:Max. 50mA(disconnection of the load)			
Insulation resistance	Min. 100MΩ (at 500VDC)			
Dielectric strength	750VAC 50/60Hz for 1 minute (Between all terminals and case)			
Connection	Cable outgoing type, 200mm cable outgoing connector type			
Mechanical specification	Starting torque	Shaft Type : Max. 40gf · cm(0.004N · m), Holl Type : Max. 50gf · cm(0.005N · m)		
	Moment of inertia	Max. 40g · cm <sup>2</sup> (2×40 <sup>-6</sup> kg · m <sup>2</sup> )		
	Shaft loading	Radial : Max. 2kgf, Thrust : Max. 1kgf		
	Deviation of shaft position	Radial : Max. 0.1mm, Thrust : Max. 0.2mm		
	Max. allowable revolution	(*Note2) 5000rpm		
Vibration	1.5mm amplitude at frequency of 10 ~ 55Hz in each of X, Y, Z directions for 2 hours			
Shock	Max. 50G			
Ambient temperature	-10 ~ 70℃ (at non-freezing status), Storage:-25 ~ 85℃			
Ambient humidity	35~85%RH, Storage: 35~90%RH			
Protection	IP50 (IEC specification)			
Cable	5P, φ 5mm, Length : 2m, Shield cable (Line driver output : 8P, φ 5mm)			
Accessory	φ 6mm coupling standard, φ 8mm coupling (Option) [Applied only for shaft type]			
Weight	Approx. 120g			
Approval	CE (Except Line driver output)			

\* (\*Note1) \* pulse is only for A, B phase (Line Driver output is A,  $\bar{A}$ , B,  $\bar{B}$  phase)

\* (\*Note2) Max. allowable revolution ≥ Max. response revolution [Max. response revolution (rpm) =  $\frac{\text{Max. response frequency}}{\text{Resolution}} \times 60 \text{ sec}$ ]

Please select the resolution to make lower max. revolution than max. allowable revolution.

(A) Counter

(B) Timer

(C) Temp. controller

(D) Power controller

(E) Panel meter

(F) Tacho/Speed/Pulse meter

(G) Display unit

(H) Sensor controller

(I) Proximity sensor

(J) Photo electric sensor

(K) Pressure sensor

(L) Rotary encoder

(M) 5-Phase stepping motor & Driver & Controller

# E40 Series

## Control output diagram

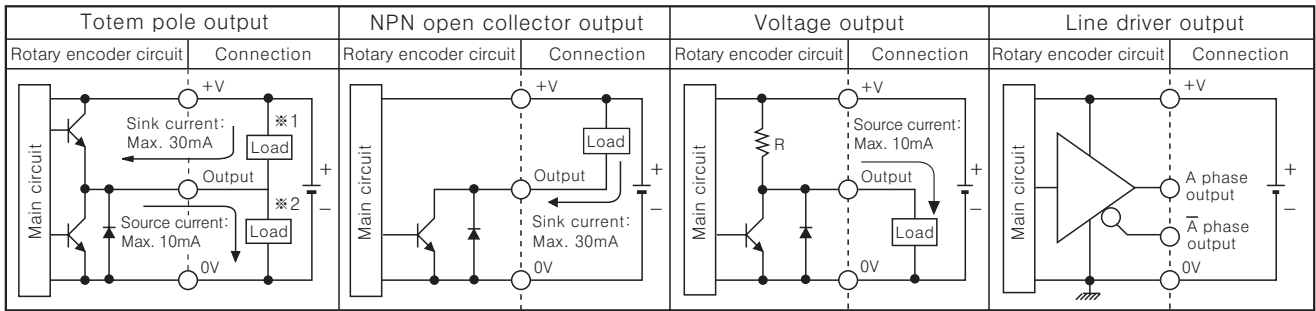

☞ Totem pole output type can be used for NPN open collector output type(\*1) or Voltage output type(\*2).  
 ☞ All output circuits are the same A, B, Z phase(Line driver output is A,  $\bar{A}$ , B,  $\bar{B}$ , Z,  $\bar{Z}$ )

## Output waveform

- Totem pole output / NPN open collector output / Voltage output
- Line driver output

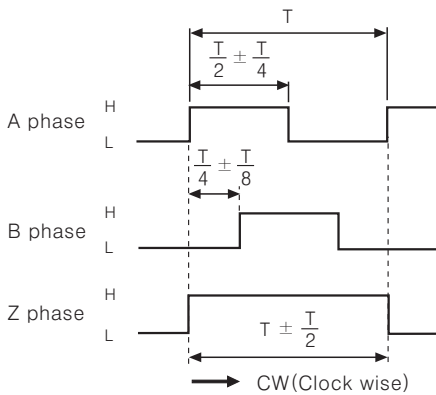

※ Inverse type of Z phase is optional.

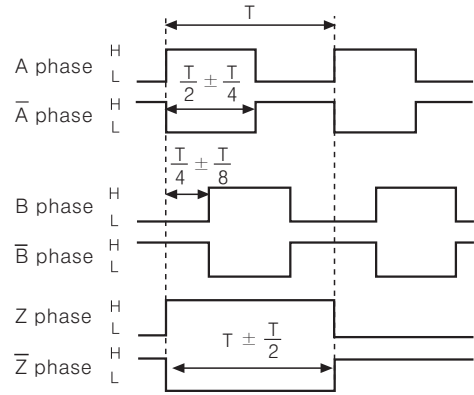

※ CW : In a view of shaft

## Connections

### Normal type

- Totem pole output / NPN open collector output / Voltage output

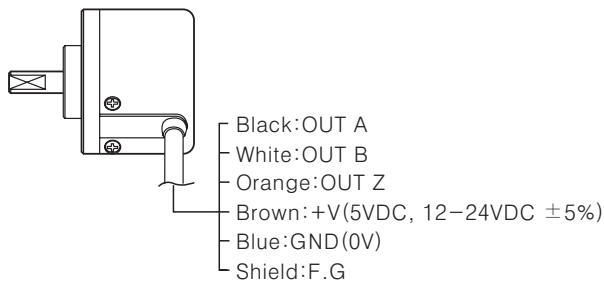

- ※ Unused wires must be insulated.
- ※ The body of encoder is connected to a shield.

- Line driver output

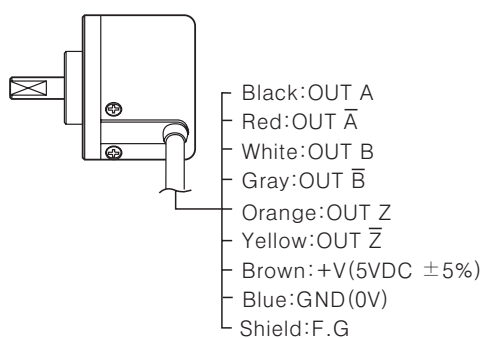

### Cable outgoing connector type

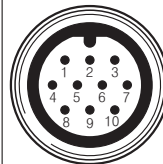

Pin No.	Cable color	Totem pole output NPN open collector output Voltage output	Line driver output
①	Black	OUT A	OUT A
②	Red	N.C	OUT $\bar{A}$
③	Brown	+V	+V
④	Blue	GND	GND
⑤	White	OUT B	OUT B
⑥	Gray	N.C	OUT $\bar{B}$
⑦	Orange	OUT Z	OUT Z
⑧	Yellow	N.C	OUT $\bar{Z}$
⑨	Shield	F.G	F.G
⑩	Purple	N.C	N.C

- ※ N.C (Not Connected)
- ※ F.G (Field Ground)

# φ 40 Body Standard / Hollow Shaft Type

## ■ Dimensions

### ■ Normal type

#### ● Shaft type

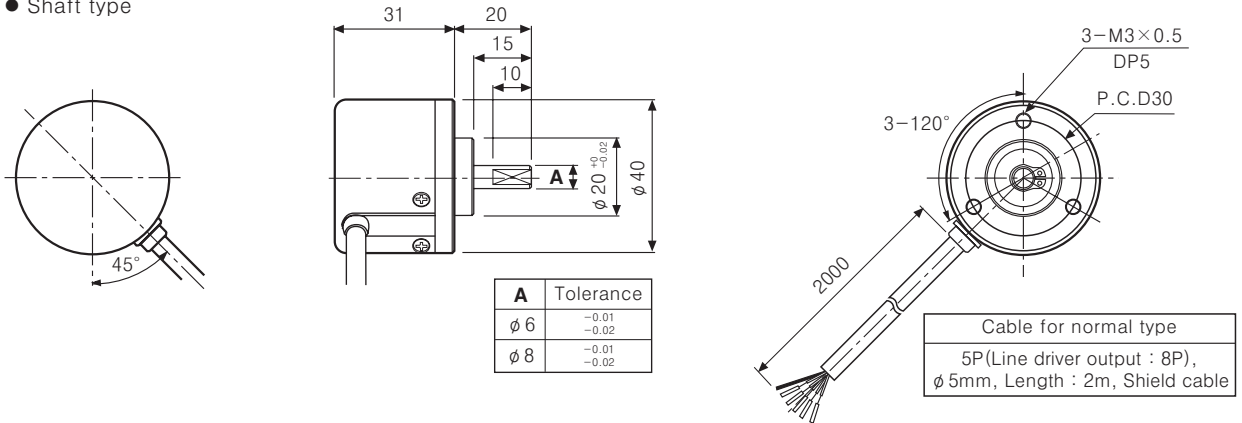

#### ● Hollow shaft / Hollow shaft built-in type

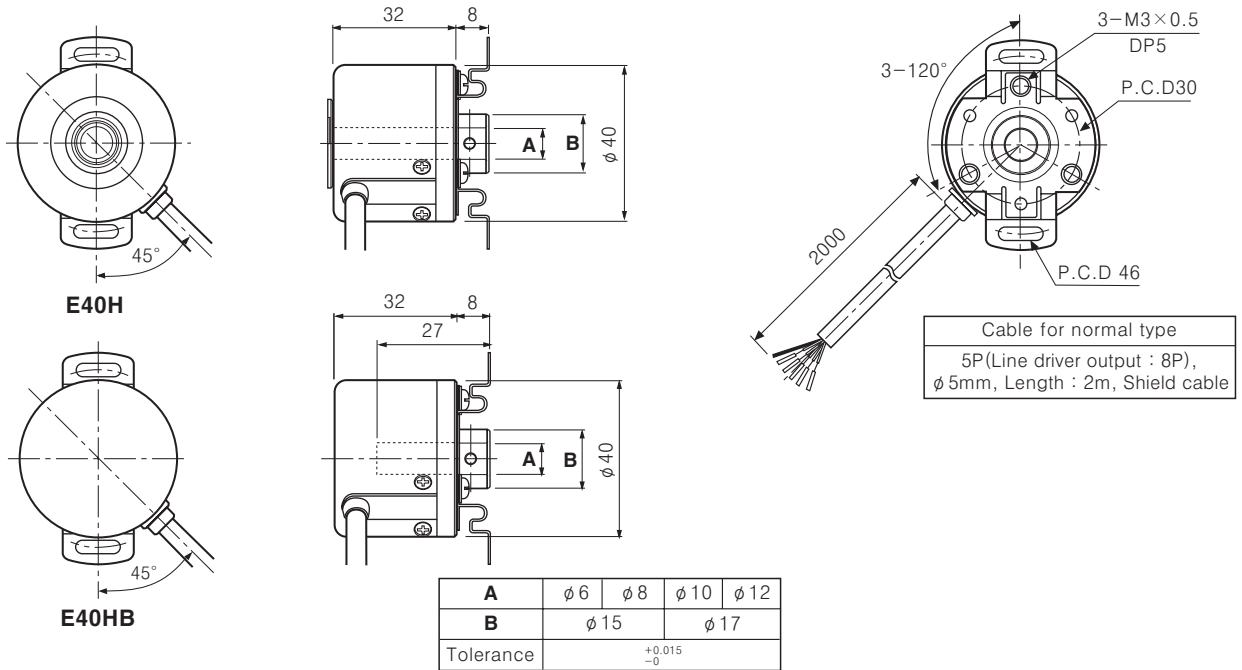

### ■ Cable outgoing connector type

#### ● Connector cable(Accessory)

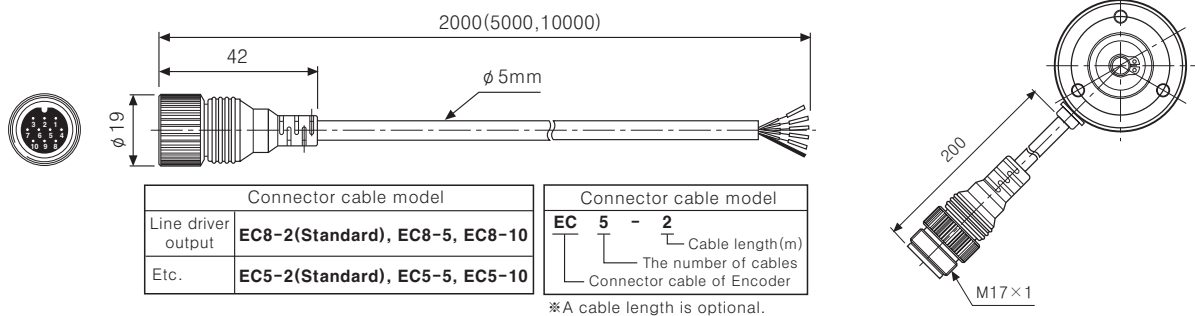

#### ● Coupling(E40S)

##### [ φ 6 Coupling]

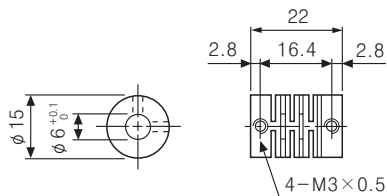

##### [ φ 8 Coupling]

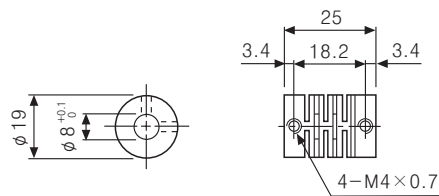

Unit: mm

(A)  
Counter

(B)  
Timer

(C)  
Temp.  
controller

(D)  
Power  
controller

(E)  
Panel  
meter

(F)  
Tacho/  
Speed/  
Pulse  
meter

(G)  
Display  
unit

(H)  
Sensor  
controller

(I)  
Proximity  
sensor

(J)  
Photo  
electric  
sensor

(K)  
Pressure  
sensor

(L)  
Rotary  
encoder

(M)  
5-Phase  
stepping  
motor &  
Driver &  
Controller